

Anschluss / Connection			Anwendung / Application							
RJ45 PIN Nr./No.	Farbcode / Colour code T568		DIN 47100	Industrial	10BT/100BT	Gigabit Ethernet	Token Ring ISDN/So	TP-PMD/ATM	ISDN/So	Upo/TEL
	A	B								
1	WH-GN	WH-OG	WH	YE	•	•				
2	GN	OG	BN	OG	•	•				
3	WH-OG	WH-GN	GN	WH	•	•	•		2a	
4	BU	BU	YE	-		•	•		1a	•
5	WH-BU	WH-BU	GY	-		•	•		1b	•
6	OG	GN	PK	BU	•	•	•		2b	
7	WH-BN	WH-BN	BU	-		•	•			
8	BN	BN	RD	-		•	•			

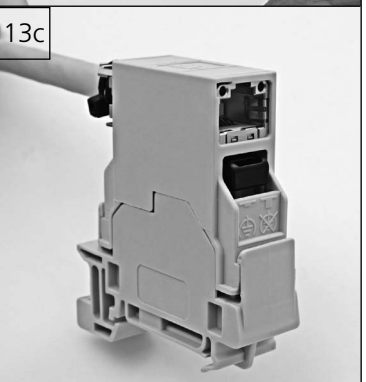

D 895030A0312b / 4350760000 2.08.2017 © by Weidmüller • Druckfehler und technische Änderungen vorbehalten / Printing errors and technical changes reserved

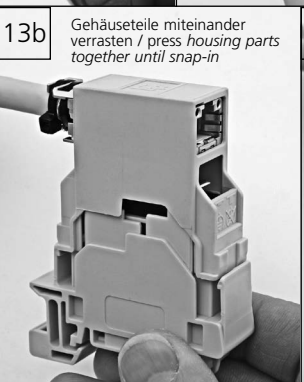
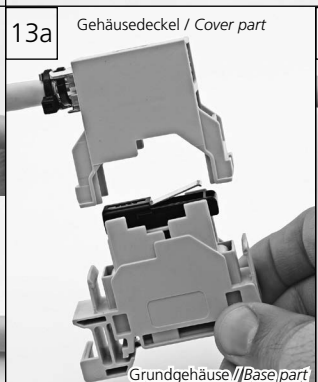
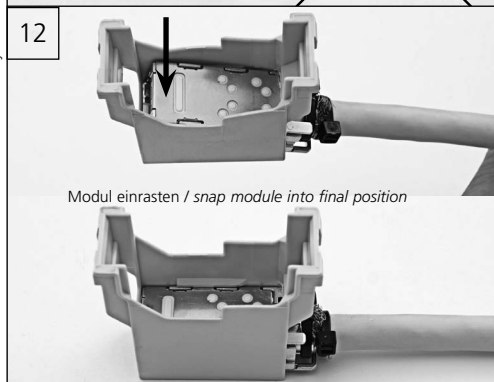
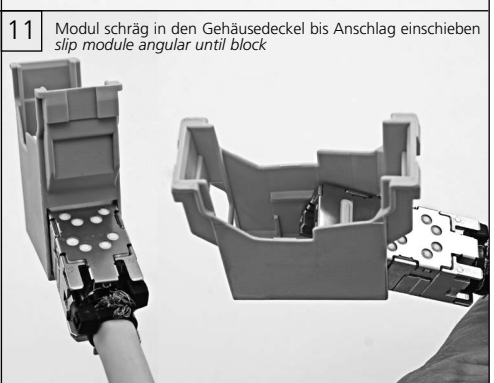
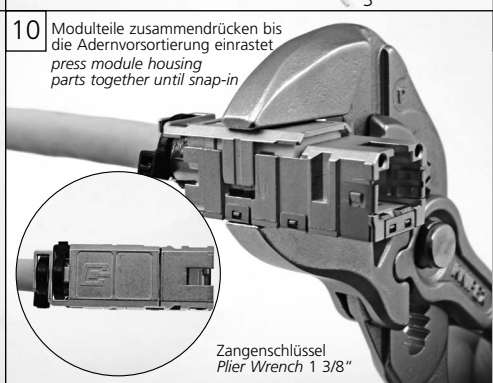
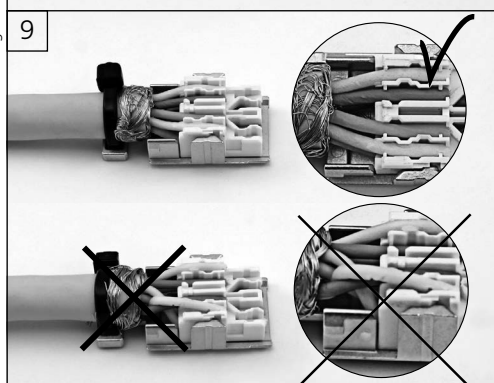
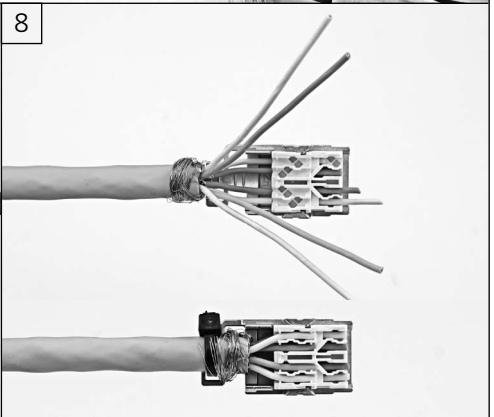
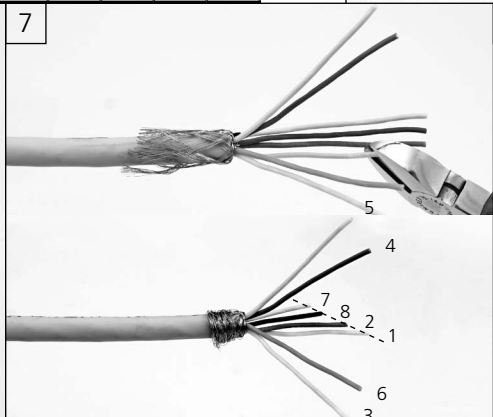
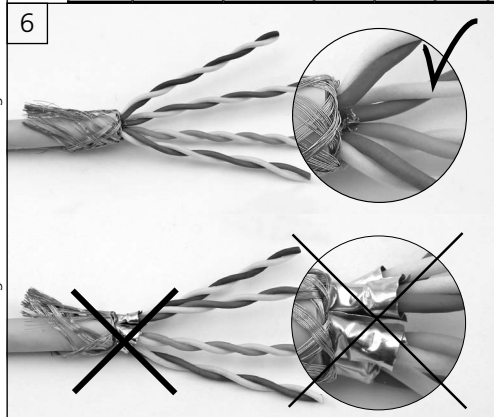
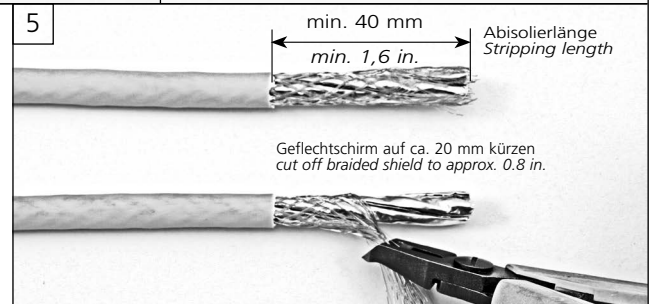
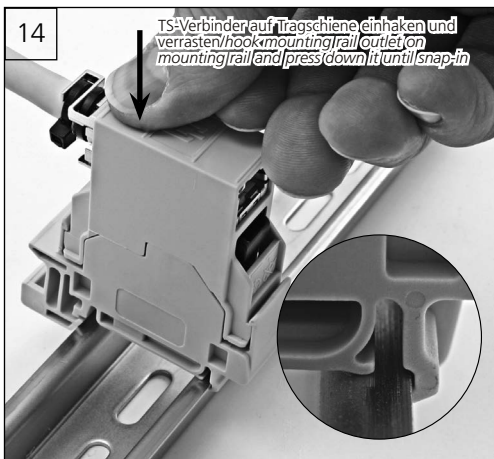

14

TS-Verbinden auf Tragschiene einhaken und verrasten / hook mounting rail outlet on mounting rail and press down it until snap-in

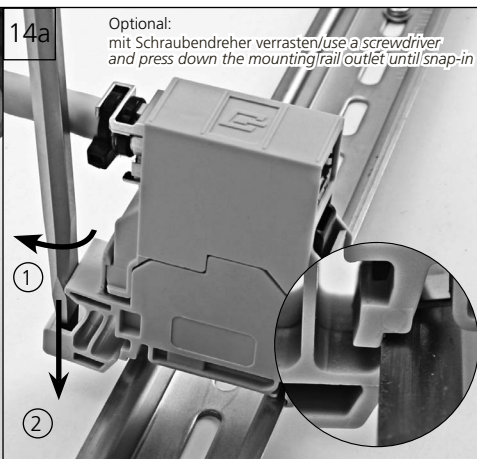

14a

Optional: mit Schraubendreher verrasten / use a screwdriver and press down the mounting rail outlet until snap-in

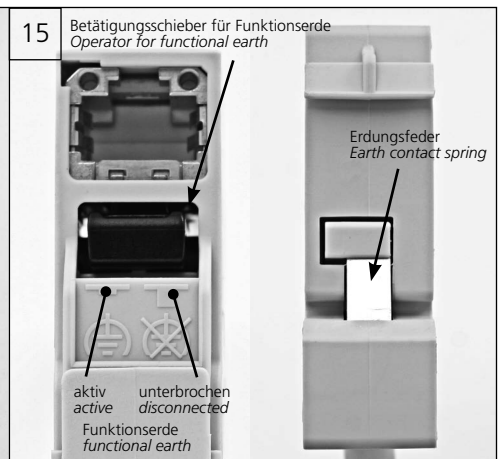

15

Betätigungsschieber für Funktionserde / Operator for functional earth

Erdungsfeder / Earth contact spring

aktiv / active
unterbrochen / disconnected
Funktionserde / functional earth

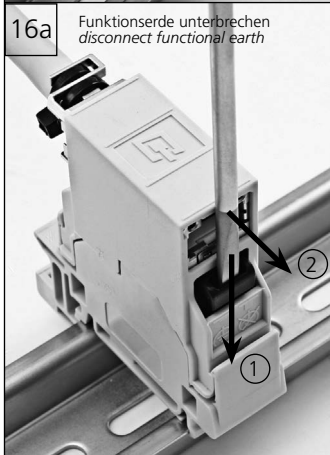

16a

Funktionserde unterbrechen / disconnect functional earth

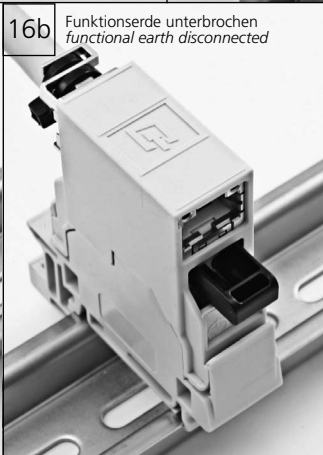

16b

Funktionserde unterbrochen / functional earth disconnected

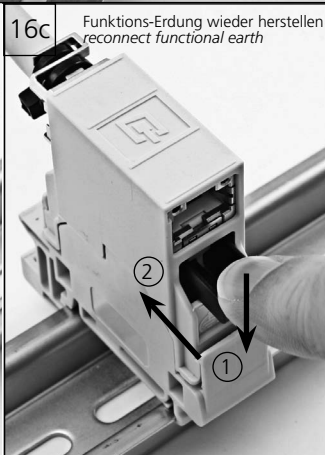

16c

Funktions-Erdung wieder herstellen / reconnect functional earth



17

Betätigung des Schieber im angeschlossenen Zustand / use of operator when jack is mated

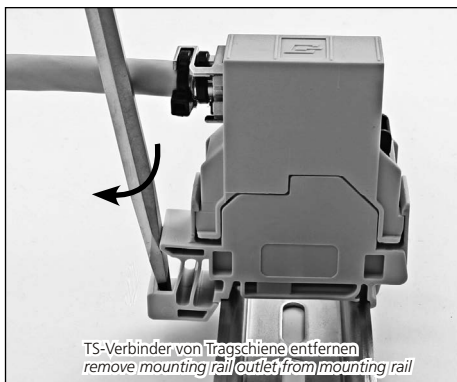

TS-Verbinden von Tragschiene entfernen / remove mounting rail outlet from mounting rail

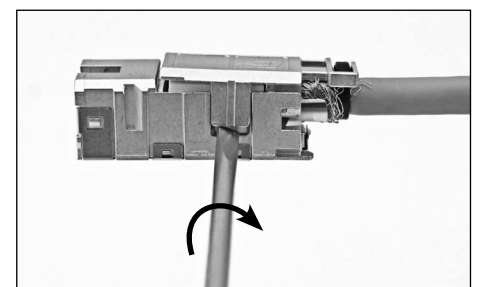
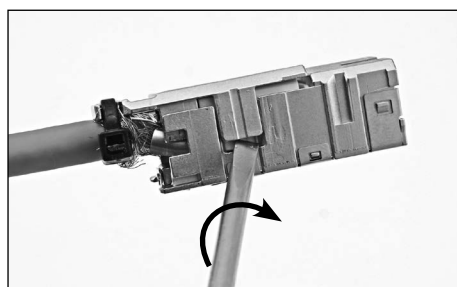
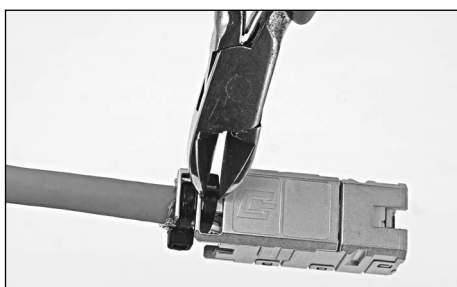
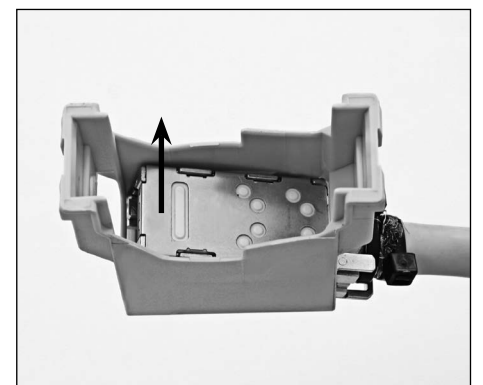
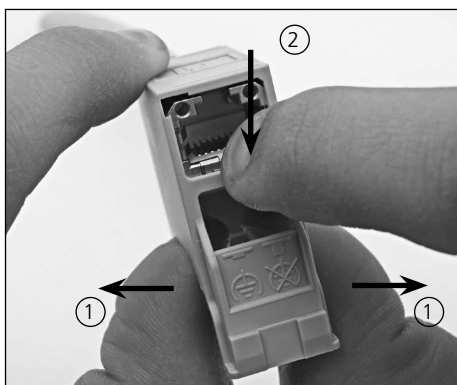
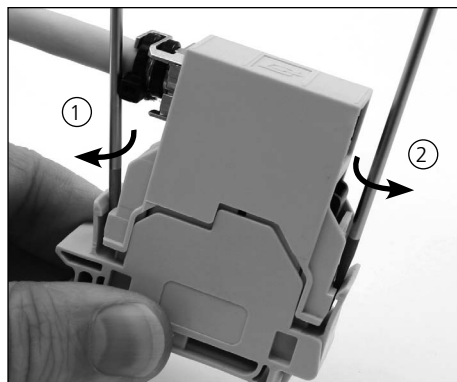

Weitere Demontageschritte nach Montageanleitung / further demounting steps according to the mounting instructions